

DZOFILM
MAKE YOUR MOVIE

Pictor Zoom Cinema Lens
Users' Manual

20-55 T2.8
50-125 T2.8

绘梦师系列
电影镜头使用说明书

www.dzofilm.com

Introduction

Pictor Zoom series lenses are the products of DZOFILM for S35 cameras.

Thank you for your purchase of this product. Be sure that you have read this manual and understood its content before using the camera. Keep the manual where it will be read by all who use the product.

For repair, inspection and internal test, please contact your DZOFILM dealer.

Make sure that you use the lens correctly. Read the Manual carefully before use.

Product Care

- When using a matte box, do not pick up or hold the camera using only the hood.
- Use a blower to remove dust and lint from the glass surfaces of the lens or filter. To remove smudges and fingerprints, apply a small amount of lens cleaner to a soft, clean cotton cloth or lens-cleaning tissue and clean from the center outwards using a circular motion. Do not leave smears or touch the glass with your finger.
- Never use organic solvents such as paint thinner or benzene to clean the lens.
- Attach the front and rear caps when the lens is not in use.
- Store the lens and filter in cool, dry locations to prevent mold and rust. Do not store in direct sunlight or with naphtha or camphor moth balls.
- Please keep the lens dry and wipe the water droplets off if there are droplets on the glass surface.
- Leaving the lens near heater or in other extremely hot locations could cause damage or warping.
- There may be a case that the glasses of the lens mist when the lens is carried from a cool place to a high temperature and high humidity. To avoid a mist on the glasses, before using the lens, let the lens adjust to the ambient temperature of the place where the lens will be used.

Supplied Accessories

- Front cap
- PL mount
- Supporting base
- Case for shims
- Zoom lever (detachable)
- DZOFILM QC & Support Card
- Screws for PL bayonet (M2*5, 12pcs)
- 2,5mm hexagon driver (for supporting base)
- Shims * 1set (T0.3*1; T0.1*1; T0.05*1; T0.03*2; T0.02*2)
- EF rear cap
- PL rear cap
- Case for shims
- Supporting rod*2
- Pictor Zoom Sticker
- T6 Trox driver (for bayonet)
- Screws for Supporting base (M3*8, 8pcs)

Parts of the Lens

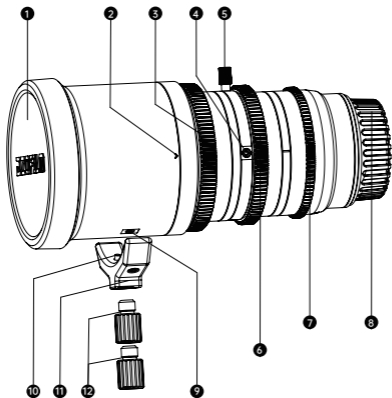

- ☒ Front cap
- ☒ Markings
- ☒ Focusing ring
- ☒ Zoom lever socket*4 (M3*4mm)
- ☒ Zoom lever
- ☒ Zoom ring
- ☒ Iris ring
- ☒ EF rear cap
- ☒ Socket for supporting base*2 (M3*3mm)

Attach the Lens to the Camera

Remove the body cap from the camera and the rear cap from the lens. Place the lens on the mount, keeping the marks on the lens and the camera aligned, and then rotate the lens until it clicks into place. Note that in some cases there may not be a mounting mark on the camera body.

When attaching the lens, ensure that dust or other foreign matter does not enter the camera and be careful not to touch the camera's internal parts. Do not press the lens release button while attaching the lens and be sure the latch has securely clicked into place.

Before using the lens for the first time or after attaching it to a different camera, measure the flange-back distance.

Lens Control

Use the lens controls to zoom in to zoom out, adjust aperture or focus.

Focus

Rotate the focus ring to increase or decrease the focus distance.

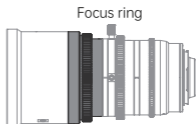

Zoom

Rotate the zoom ring to zoom out, increasing the area visible in the frame or zoom in on the subject so that it fills a larger area in the frame.

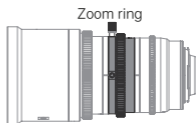

Aperture

Rotate the aperture ring to stop aperture down, raising T-stop narrowing the aperture, or lower the T-stop the aperture.

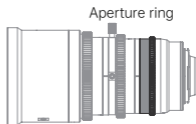

How to Adjust Back Focus of Pictor Zoom

Pictor Zoom series lenses will all go through flange back test with shims based on S35 standard before shipping, but flange back distance can vary on different cameras. If the flange back distance is incorrect, the camera will not focus at the correct distance.

- 1.To start with, prepare a Siemens Star chart, or other black-and-white (high-contrast) resolution chart to test;
- 2.Attach your Pictor Zoom lens to the camera;
- 3.Rotate the iris to wide open;
- 4.Set up Siemens Star chart at 1.5M(4.9 Feet) away from the camera (flange), and make sure the target is in the image center.
 - A. Zoom in to the longest focal length, focus on the target until the target is sharpest, and mark down the focus distance as S1.
 - B. Zoom out to the widest, focus on the target until the target is sharpest, and mark down the focus distance as S2.
 - C.If the figure $S2 < S1$, increasing shim(s) is needed; If $S2 > S1$, then reduce the shim(s).
 - D.Repeat step A to C until $S2=S1$. At this moment the lens is under Parfocal.

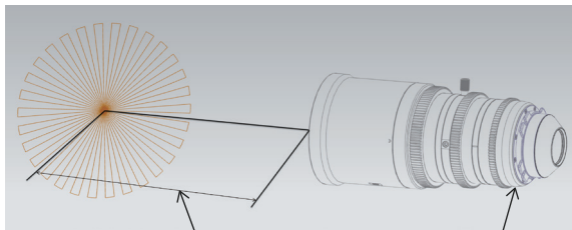

The testing target should lay on the center of image, and 1.5M away from the camera sensor

Maximum T-stop

Table for flange distance adjustment

55mm object distance at best focus S1	20mm object distance at best focus S2	Change of total shim thickness(mm)
1.5m	0.9	+0.36
	1	+0.27
	1.1	+0.19
	1.2	+0.14
	1.3	+0.1
	1.4	+0.05
	1.5	0
	1.7	-0.04
	2	-0.1
	2.5	-0.16
	3	-0.18
	3.5	-0.2
	4.5	-0.24
	6	-0.27
10	-0.3	

Table for flange distance adjustment

125mm object distance at best focus S1	50mm object distance at best focus S2	Change of total shim thickness(mm)
1.5m	1.3m	+0.33
	1.35m	+0.2
	1.4m	+0.12
	1.5m	0
	1.6m	-0.1
	1.7m	-0.25
	1.8m	-0.37

PS: This table is only for reference

Minus sign: Shims need to be removed; Plus sign: Shims need to be added

Assemble PL Mount

Align the groove under the PL bayonet to the positioning pin. Place the bayonet plat on the rear of the lens;

Slightly twist the mount, and make sure the bayonet is in plat condition;

Finally drive 8pcs M2*5 screws into screw holes in symmetrical order

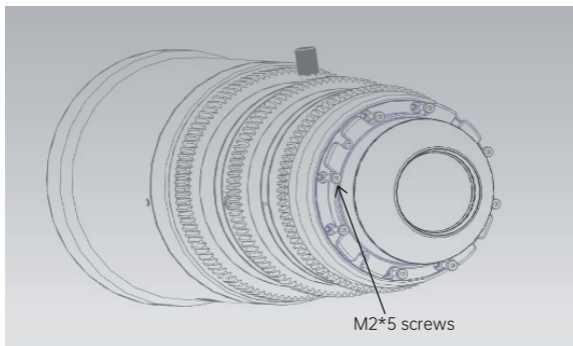
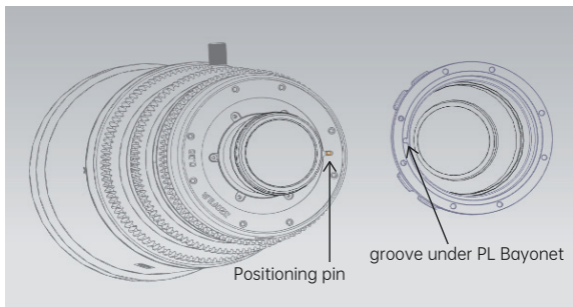

Assemble EF Mount

Align the groove under the EF bayonet to the positioning pin. Place the bayonet plat on the rear of the lens;

At this moment, the groove on the surface shall align the Arrow Mark and Reticle. If not, that means the position of bayonet is incorrect.

Slightly twist the mount, and make sure the bayonet is flat;

Finally drive 7pcs M2*18 screws into screw holes in symmetrical order.

PS. After changing the mount into EF mount, the rear glass element exceeds the mount a little bit. Do not place this end on the desk without rear cap in order to avoid scratches.

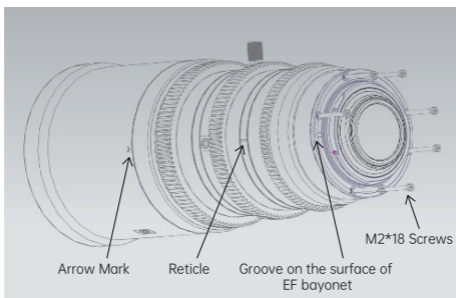
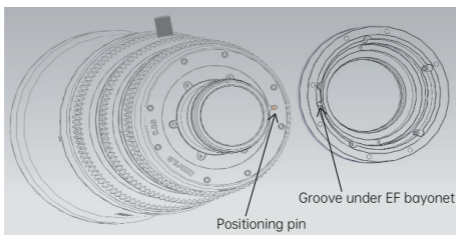

Specification

Specifications	20-55	50-125
Lens mount	EF/PL	EF/PL
Focal length	20-55 mm	50-125 mm
Zoom ratio	2.75X	2.5X
Minimum T-stop	T2.8	T2.8
Aperture range	T2.8-T22	T2.8-T22
Image Circle	24.89 mm*19.3 mm (φ31.5 mm) ratio 1.33:1	24.89 mm*19.3 mm (φ31.5 mm) ratio 1.33:1
Flange Distance	52mm(PL) / 44.14mm(EF)	52mm(PL) / 44.14mm(EF)
Close Focus Distance (to sensor)	0.6m/2ft	0.8m/2ft8in
FOV.		
Horizontal	64.3°- 24.8°	28.1°-10.8°
Vertical	49.6°- 19.0°	20.9°-8.2°
Diagonal	78.0°- 30.6°	35.8°-13.3°
Shooting Area under Close Focus	20mm: 547 mm * 24.8mm	50mm: 348 mm*257 mm
	55mm: 193mm*146 mm	125mm: 132mm*100 mm
Effective lens Dia.		
Front	53.0 mm	61.0 mm
Back	25.8 mm	29.4 mm
Aperture control	Manual (ring rotates up to 65°)	Manual (ring rotates up to 72°)
Zoom control	Manual (ring rotates up to 100°)	Manual (ring rotates up to 100°)
Focus control	Manual (ring rotates up to 270°)	Manual (ring rotates up to 270°)
Size:	φ95.0*164mm(PL) φ95.0*171.9mm(EF)	φ95.0*175mm(PL) φ95.0*182.9mm(EF)
Weight:	≈1520g	≈1700g
Front Outer Dia.	φ95 mm	φ95 mm
Filter Size	M86*0.75	M86*0.75
Gear Pitch (aperture, zoom, and focus)	0.8 M	0.8 M
Number of blades	16 Pcs	16 Pcs

*Improvements may result in unannounced changes on specification and appearance. Owing to how this lens is constructed the distance shown by the camera focus distance indicator (distance indicator) may in some cases differ from the actual focus distance. (Use the "distance indicator" as a guide only).

Appearance

20-55

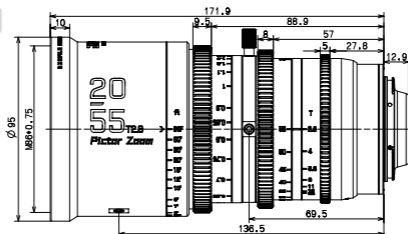

50-125

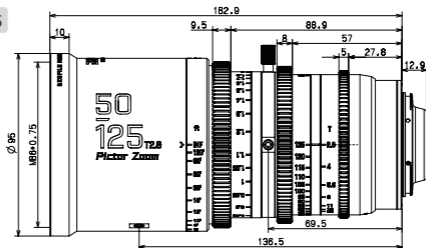

Repair and Maintenance

Repairs

Return the product to the point of purchase for repairs. Please note that we reserve the right to refuse service in the event of damage so severe that there is little hope of function being restored, whether said damage is caused by physical shocks, immersion in sand, mud, or water or the like.

Warranty service

Should the product malfunction in the course of normal use as set forth in the users' manual and accompanying documentation, it may

be returned to the point of purchase for repairs within warranty period. The owner is responsible for all shipping costs. The warranty period varies with the country or region of purchase. Stored dated receipts or other proof of purchase in a safe place, as it will be required for repairs made under warranty.

Service Outside the Warranty Period

Request for service will normally be accepted within a period of roughly 5 years following the end of production, during which time spares will be kept on hand, although owners may be offered an equivalent product during this period in the event that spares are not available. Compatibility with consumables and accessories for the original product is not guaranteed. To prevent waste, repairs or replacement may be made using refurbished parts or products, and DZOFILM may collect returned parts or products for later use. When returning a product for repair, please let us know if you need the original parts.

Privacy

DZOFILM obeys all applicable laws and regulations concerning the handling of names, addresses, phone numbers, and other personal information provided by users.

Shenzhen Dongzheng Optical Technology Co., Ltd.

1F., Building One, Xinwuxia Industrial Park, No.32, Cuibao Rd., Baolong St., Longgang Dist., Shenzhen 518000, China

 +86 755-2890 8505

 www.dzofilm.com

深圳市东正光学技术有限公司

广东深圳市龙岗区宝龙街道翠宝路32号
新屋吓工业园1栋1楼

 0755-2890 8505

 www.dzofilm.com