

audiowireless

AWDR-1 Receiver

Small, true-diversity receiver for broadcast, ENG and location recording, with internal or external powering

User Manual

v1.0



Contents:

Foreword.....	1
Safety Instructions	1
Product Contents	1
General Description	2
True Diversity.....	3
Product Overview.....	4
Audio Output Sockets.....	4
Headphone Monitoring Socket	4
The LED Indicators.....	5
RSSI Active ‘A’ and Active ‘B’ (Tri-colour LED).....	5
Receiver Battery Status (Tri-colour LED).....	5
Transmitter Battery Status	5
Antenna Input Socket A & B.....	5
Push Button Controls	6
Frequency Label.....	7
Battery Compartment	7
LCD Display	8
Using the AWDR-1.....	11
Tuning the Receiver	11
Tuning By Frequency.....	11
Saving Custom Frequencies.....	11
Tuning By UHF TV Channel and Sub-Channel.....	12
Unit Name	13
Display settings	13
SCAN	13
AUDIO.....	13
Phase	14
Headphone Volume.....	14
Mute Level / Squelch: “MUTELV”	14
Unit Information: “INFO”	14
Pilot Tone	15
Power Settings (On-Mode).....	15
Resetting Preferences.....	15
Locking and Unlocking the Unit.....	16
Further Technical Information	17
Antenna Data for Flexible Wire Antennae	17
Model Variants and Switching Bands:	18
Audio Connector Details.....	19
Cable End Connectors	19
Standard Receiver Cables Details.....	20
Technical Specifications	23
RF Transmission System	23
Audio Performance.....	23
Received Signal Strength Indicators (RSSI).....	23
Battery Status Indicator	23

TX Low Battery Indicator	24
Headphone Monitoring Output	24
Powering	24
Connectors	24
Dimensions.....	24
Accessories	24

Foreword

Thank you for choosing Audio Wireless

We aim to offer the best quality products alongside a quick and reliable service for all our customers. Please take some time to read our instruction manual to ensure you get the most out of our equipment.

Safety Instructions

- Please read these instructions carefully before using the unit to avoid injury and damage to your AWDR-1 unit.
- Always include these instructions when passing the unit on to third parties
- Never open the electrical units; if the units are opened then the warranty becomes null and void.
- Protect the unit from damp and wet conditions, as water entering inside can cause damage to the unit.
- Use only a slightly damp cloth to clean the unit. Do not use any cleansing agents or solvents.

Product Contents

- 1 AWDR-1 Diversity Receiver
- 2 Antenna
- 1 Quick Start Guide
- 1 Carrying Case

General Description

The AWDR-1 Diversity Receiver offers the greatest flexibility and sound quality for crews, operators and sound recordists, whether working internationally or simply under challenging RF conditions.

Its sophisticated structure comes in a lightweight yet rugged, CNC machined aluminium case, designed for extra strength and durability as well as the ability to withstand the heavy demands of location use.

The unit requires two AA batteries which fit into its unique battery compartment designed for fast and easy battery replacement by an easy-twist compartment cover, with a reassuring click-stop mechanism. Alternatively it can be externally powered from any 10-18V source.

Product Features:

- Switching bandwidth up to 120MHz
- Tunable in 25kHz steps
- Digitally switchable RF front-end
- Top-level flexibility for international working
- Compact design, tough, lightweight aluminum case
- 2 x AA alkaline batteries provide approximately 5 hours of operating time or using lithium batteries even longer
- Easy-twist battery compartment cover, with click-stop reassurance
- External powering capable with adaptor leads
- Balanced user adjustable audio output
- Audio output level from +6dBV to -42dBV
- Headphone - Stereo/mono mini-jack with monitor-volume control
- Easy operation by backlit LCD with programmable functions
- Continuous Rx and Tx low battery status indicators
- RF, Pilot-tone and noise operated mute
- Reliable, professional-grade connectors

Please Note:

To ensure best performance it is recommended to only use the AWT-1 transmitter series with the AWDR-1 diversity receiver series.

True Diversity

The Audio Wireless diversity receiver systems give a dramatic improvement to signal dropout problems found in dead spots when compared to other simple standard or antenna switching receivers. This is because the true diversity receiver makes use of two RF signals, and when one antenna is receiving a weak signal, the other antenna will be receiving a stronger signal, offering greater reliable coverage.

The problem of signal dropout is usually caused where the direct and reflected signals happen to interfere and cancel each other out at the antenna. Within the Audio Wireless diversity receiver the combining circuitry automatically discards the output from the receiving sections of weaker RF signal before it can degrade the audio output. Should the signal strengths be similar the audio outputs are combined to improve the signal to noise ratio. This audio mixing gives a 3dB improvement over conventional switched diversity receivers and results in a greater operating range.

By fully processing (demodulating) both signals and not simply switching at the Antenna level a robust and reliable AF signal can be transmitted with no audible dropouts and the best signal to noise ratio can be maintained over a large reliable operating area.

Furthermore the same result could not be achieved by just connecting two antennas in parallel, either directly or through simple amplifiers. The relative phase of the signals from the two antennas would change as the transmitter was moved and cancellation effects would occur at the summing point.

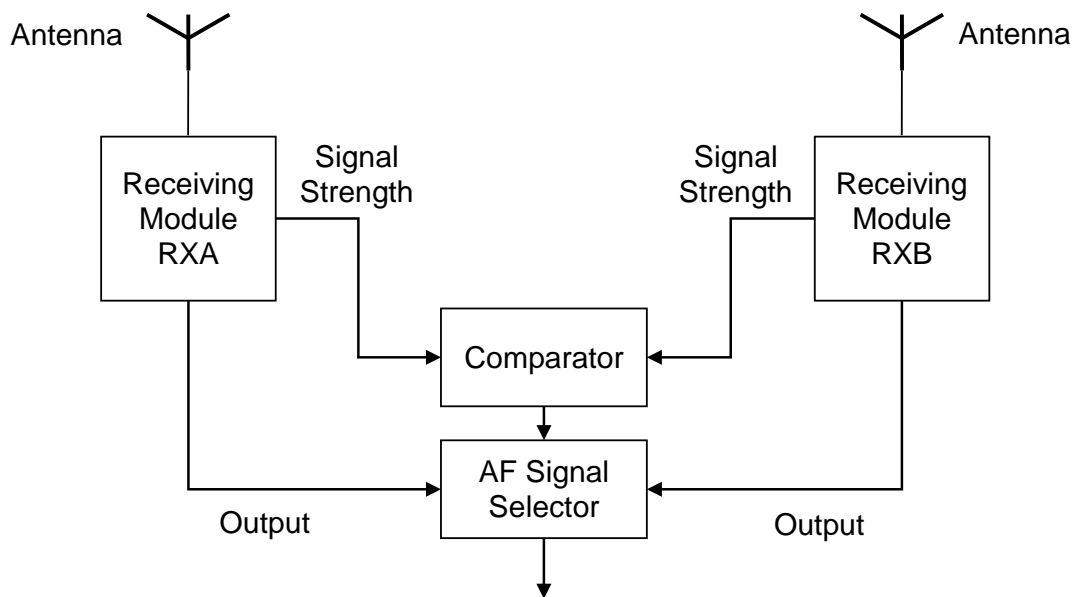

Product Overview

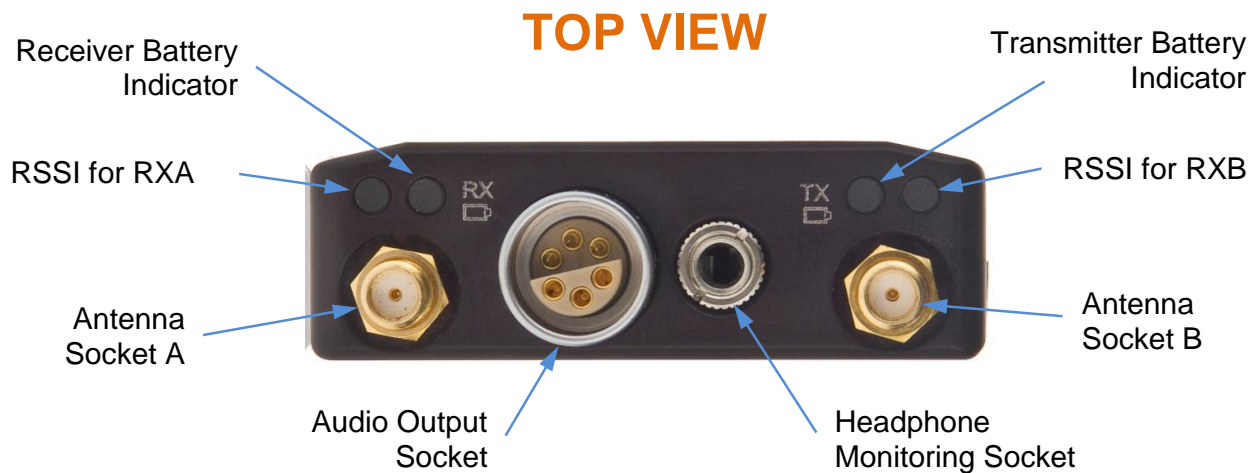

Audio Output Sockets

There are two types of Audio Output connectors available:

- Large 6-Pin LEMO™ connector (pictured above)
- Multi-way 4-pin connector HR4

Both connectors provide balanced audio output and external dc input connections to the receiver. The balanced audio output level is user adjustable from +6dBV to -42dBV to suit varying device input requirements. External powering may be done by using dedicated RCP cables.

Please Note:

Ensure that P48 is turned off on a mixer/camera before connecting it to the AWDR-1.

Headphone Monitoring Socket

The AWDR-1 has a unique headphone design that auto detects Stereo or Mono Jacks when inserted into the 3.5mm socket and does not cause an electrical short or any loss of audio level. The Headphone is user adjustable to suit headphones impedances as low as 16Ω.

Please Note:

Make sure that the Headphone Amplifier is OFF (00) when not used. High levels of volume can damage your hearing, always set the Monitoring level low before connecting headphones and then adjust as required.

The LED Indicators

RSSI Active 'A' and Active 'B' (Tri-colour LED)

A tri-colour LED above each antenna socket continuously display the Received Signal Strength Indicators (RSSI) and shows which half of the Diversity Receiver is Active.

Receiver Battery Status (Tri-colour LED)

A tri-colour LED continuously displays the internal/external battery status.

Transmitter Battery Status

Transmitter low battery-warning Red-LED lights up/flashes when the supply voltage of the corresponding TX has fallen to below ~1.0 Volt.

The Low Battery Warning period depends upon the type of battery used.

Antenna Input Socket A & B

The miniature 50Ω SMA coaxial sockets are used as the antenna input connectors, the detachable matching antennas are fitted by a simple screw-on action.

FRONT VIEW



Push Button Controls

All user adjustments to the AWDR-1 are made via three push buttons. Primarily use the **UP** and **DOWN** to scroll through menu's and the **SET-PWR** to select choices. Alternatively at any time the **SET-PWR** button can be held down to turn the receiver OFF (and back ON) and by holding both the **UP** and **DOWN** buttons the receiver can be LOCKED.

Frequency Label

Indicates the tuning range of the receiver, where it is possible to tune to frequencies within this range in steps of 25 kHz. Alternatively the user may tune the Receiver to standard UHF TV channels with pre-coordinated sub channels.

Battery Compartment

The AWDR-1's AA batteries are held in place by a captive, easy-twist compartment cover, with a click-stop mechanism for quick, reliable changes possible by feel alone.

Simply open the battery cover by rotating clockwise, insert 2 AA batteries (please follow the polarity guidance) into the compartment. The click system reassures that the compartment is fully opened or closed.

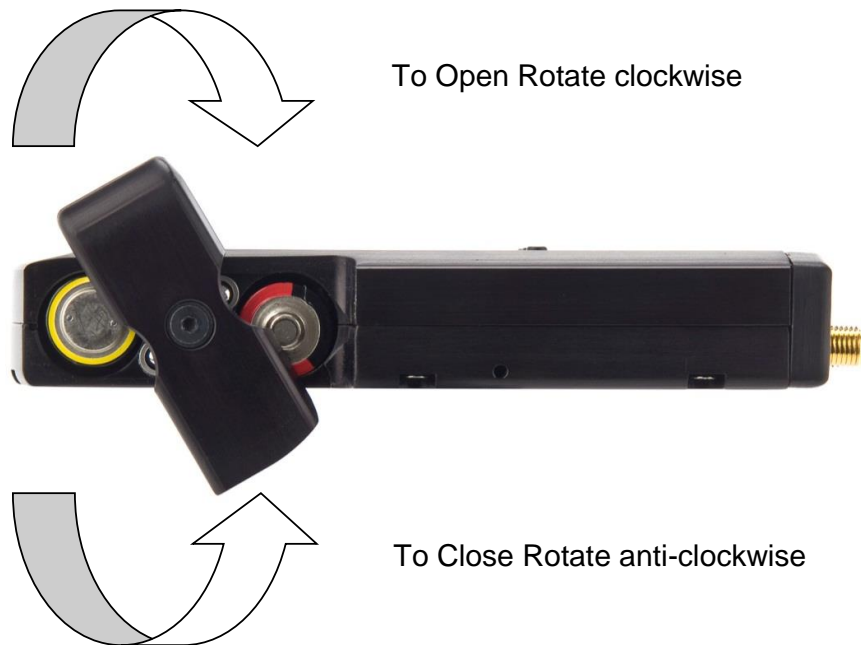

Please Note:

When inserting the batteries please remember to follow the polarity guidance indicated on the rear face of the unit. Remove the batteries when the unit will not be used for extended periods of time.

LCD Display

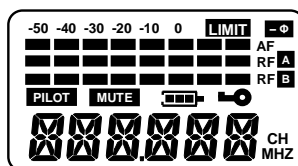



The backlit multifunction LCD display provides clear access to all the available control menus and functions of the AWDR-1. Permanently displayed, irrespective of the currently selected menu, is the continuous AF metering of the audio signal level and RSSI level of each antennae's RF signal and the battery level icons.

Please Note:

The display backlight and LED indicators (when active) illuminate for approximately 15 seconds from last button press and subsequently turn off to optimize battery use.

By default the following main menus are available:

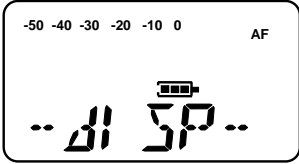
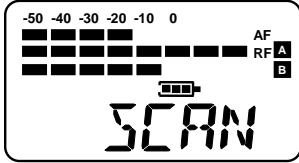
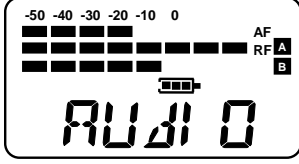
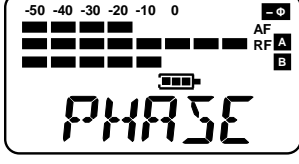
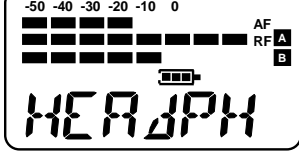
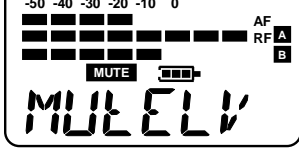
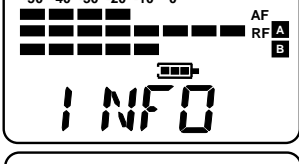
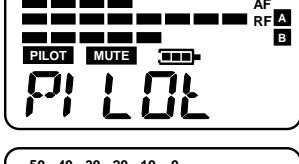
Menu Name	Example Display	Menu Description & Function
Frequency		Displays Transmission Frequency and allows for adjustment when selected
Channel		Displays Transmission Channel & Sub-Channel as well as allowing for adjustment when selected
Name		Displays Unit Name and allows for adjustment when selected

Menu Name	Example Display	Menu Description & Function
Display		Option for displaying or hiding certain Menus
Scan		Facility to find quiet frequencies (or Channels) to use or noisy signals to avoid
Audio		Set the audio output gain from +6dB to -42dB in 6dB steps
Phase		Option for inverting the phase of the output signal
Head-Phone		Allows for adjustment of the Head-Phone volume
Mute / Squelch		Allows for adjustment of the Mute (aka Squelch) level
Info.		Gives Unit Info
Pilot		Option to turn off the Pilot tone system
On-Mode		Allows for adjustment of the Power-On mode

Menu Name

Example Display

Menu Description & Function

Reset

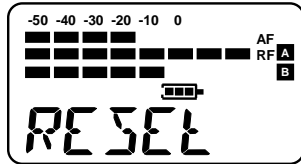

Option to return all settings to factory defaults

Lock

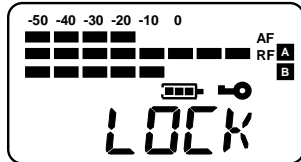

Displays current Lock state and allows adjustment of the Lock Setting

Please Note:

All menus are set to be displayed by default. However within the display menu it is also possible to choose to show only one out of the Frequency, Channel or Name menus and hence hide the other two.

Using the AWDR-1

Tuning the Receiver

There are two methods available for tuning the receiver allowing both complete flexibility and convenience. These are tuning by Frequency or by numbered UHF TV Channel with pre-coordinated Sub-Channels.

Tuning By Frequency

By default the Frequency menu is the first menu that appears upon turning ON the unit. On the Frequency menu the currently used frequency for transmission is displayed on the screen in MHz.

1. To tune, press the **SET-PWR** button to start the frequency select mode. In this mode the displayed frequency flashes.
2. Use the **UP** or **DOWN** buttons to scroll through the entire switching bandwidth in steps of 25 kHz.
3. To save the selected frequency press the **SET-PWR** button to store, the confirmatory "*SAVED*" message will appear.

Saving Custom Frequencies

The receiver can save up to 24 frequencies to the user customisable channel bank listed as "VAR XX" in the channel menu. To store a frequency - simply repeat the above but after selecting the frequency quickly press the **SET-PWR** button again whilst the "*SAVED*" message appears.

Then select the required custom channel, named "VAR 01" to "VAR 24" and hit the **SET-PWR** button to select and display the confirmatory "*SAVED*" message.

Please Note:

There are 24 user customizable channels available, which after being set in the frequency mode menu, are then accessible via the channel mode menu, explained further below.

Remember to change display mode to "All" for both menus to be available. Resetting the unit will clear all user channel pre-sets.

Tuning By UHF TV Channel and Sub-Channel

Each UHF TV channel (8MHz wide in EU) has up to 12 pre-coordinated sub-channels (labelled A through to M, excluding the letter I). These have been calculated to avoid interference between them, maximizing the use of the available spectrum. (Sub-Channels A to H are the best eight).

1. To tune to a UHF TV channel, simply hit the **SET-PWR** button whilst on the Channel Menu to start the channel select mode. In this mode the displayed channel information flashes.
2. Use the **UP** or **DOWN** buttons to scroll through all the available channels and press the **SET-PWR** button to select one. As well as the model dependent range of UHF TV channels are the user customisable “VAR-XX” channels available.
3. Use the **UP** or **DOWN** buttons to scroll through the available sub-channels and press the **SET-PWR** button to select your choice and “**SAVED**” message appears to confirm your selection. Please note, each UHF TV channel may have up to 12 pre-coordinated sub-channels, e.g. “A>M”.

Please Note:

Channel 38 (606-614 MHz), commonly used in the UK is presented with 2 sets of sub-channels. The Audio Wireless co-ordinated “A>M” set and the alternative JMFG “38-XX” option that grants a set of sub-channels numbered from 1-10. Do not mix sub-channels from both sets.

For users in the UK it should be noted that channel 38, is the only general purpose channel recommended for use by the JMFG in public spaces.

Unit Name

For convenience and quick distinction between units it is possible to give the receiver a 6 character alpha-numerical name. The characters available are A-Z, 0-9 and 3 special characters; “*”, “-” and “ ”.

By default the name given is the Units Model Number, e.g. “AWDR-1”.

Display settings

In certain usage situations it may be preferred to hide some of the menus. For example, if the receiver is to only be tuned using frequencies it may be preferable to hide the channel menu, or vice versa when tuning with UHF channels and sub-channels. Alternatively, if the device has been tuned and will not need to be adjusted for an extended period of time it may be of benefit to display only the Unit’s Name to quickly distinguish amongst other units.

The Menu Display options available are:

All – Display all Menus; Frequency, Channel and Name.

Freq – Display only the Frequency Menu & not the Channel or Name Menus.

Chan – Display only the Channel Menu & not the Frequency or Name Menus.

Name – Display only the Name Menu & not the Frequency or Channel Menus.

To change the displayed menus, simply hit the **SET-PWR** button whilst on the Display Menu to start the Display menu select mode and cause the current Display option to flash continuously. Then use the **UP** or **DOWN** buttons to cycle to the required setting and press the **SET-PWR** button to select your choice and display the confirmation “*SAVED*” message.

SCAN

With the Scan function it is possible to find a quiet, usable channel or when the “Signal” options is selected, a signal or noisy channel can be found to avoid. On the Scan Menu press the **SET-PWR** button and then with the **UP** and **DOWN** buttons select whether to scan for noise or for a free channel. Once SCAN is selected the unit will automatically search through all available pre-coordinated channels and then in 100 kHz steps starting from the lowest available frequency. Once the SCAN stops on an appropriate channel press the **SET-PWR** buttons to accept or press the **UP** button to reject and continue with the scan.

AUDIO

The Audio output level of the AWDR-1 is user adjustable between +6dBV to –42dBV to suit varying device input requirements. To do so press **SET-PWR** on the AUDIO menu, adjust with the **UP** and **DOWN** buttons and press **SET-PWR** to confirm.

Phase

A phase reverse facility is provided within the AWDR's menu system to help the users when mixed equipment might be out of PHASE or when hard wired boom and Radio mics may have different phase. To match the phase of other equipment used with the AWDR-1 is the ability to change the phase of the output. Simply select whether to INVERT the phase or keep it NORMAL.

Please Note:

When the phase invert is selected, the "Φ" icon will appear on the screen.

Headphone Volume

To adjust the volume of the monitoring output, simply select the Menu with **SET-PWR**, then use the **UP** and **DOWN** buttons until the required level is reached and select it by pressing **SET-PWR** once more.

Please Note:

Make sure that the Headphone Amplifier is OFF (00) when not required.

WARNING:

High levels of volume can damage your hearing, always set the Monitoring level low before connecting headphones and then adjust as required.

Mute Level / Squelch: "MUTELV"

The receiver is fitted with an adjustable MUTE LEVEL to mute the receiver in cases of noisy background levels or as a very useful tool when setting the receivers in a multi-channel set of 8-12 in a given TV band. This is to avoid any unwanted receiver mute activation for a reliable operation.

Unit Information: "INFO"

Within the INFO menu it is possible to view the following unit information;

Serial Number	- Unit Unique and same as on the rear casing
Model name	- E.g. "AWDR-1"
Max switching frequency	- In MHz, model specific
Min switching frequency	- In MHz, model specific
Dc volt level	- The voltage reading of the battery
Software version number	- The Software version number

Pilot Tone

The AWDR-1 and AWT-1 series feature a Pilot Tone mechanism to only output the audio signal when it is received from the corresponding matching transmitter. Use the menu to enable or disable the feature if required. **PILOT ON** is recommended.

Power Settings (On-Mode)

The AWDR-1 features two POWER-ON modes; Manual and Automatic. The Manual mode allows the unit to be turned ON and OFF holding the **SET-PWR** button. In the Automatic mode the receiver will power on as soon as a battery or external power is inserted and may be turned OFF by holding the **SET-PWR** button.

Resetting Preferences

Use this menu to reset the unit to the following Factory default settings:

- Clear all User defined channels, VAR-01 to VAR-24
- Unit Name – Unit Model name, e.g. “AWDR-1”
- Display – All
- Gain – +6dB
- Phase – not inverted
- Headphone Level – 00 (disabled)
- Mute/Squelch Level – 00dB μ V
- Pilot Tone Filter - On
- Lock Mode – Unlocked
- On Mode – Auto

To Reset the AWDR-1, press the **SET-PWR** button whilst the Reset Menu is displayed, and press the **UP** or **DOWN** button to select “OK” to reset or “NO” to cancel. To confirm your choice press the **SET-PWR** button. After resetting the “SAVED” message will be displayed.

Locking and Unlocking the Unit

The AWDR-1 is designed with a Lock function to help prevent any unwanted further changes to settings. There are two options of lock available, Lock and *Super-Lock* (“SULOCK”).

The general Lock can be activated and de-activated at any time by pressing and holding both the **UP** and **DOWN** buttons until the key icon appears or disappears on the LCD display. It can also be set via the LOCK menu and selecting “LOCK” but it can always be unlocked by holding both the **UP** and **DOWN** buttons.

The “SULOCK” mode can only be activated within the Lock menu and can only be UNLOCKED by removing the power from the unit.

Lock mode restrict any changes to any of the menu options but the unit can still be powered off by a long press of the **SET-PWR** button. When either lock mode is activated the key icon appears on all menus and “LOCK” or “SULOCK” will be displayed when attempting to change settings.

In the Lock mode Headphone volume is the only menu that is active.

Further Technical Information

Antenna Data for Flexible Wire Antennae

COLOUR CODE	CENTRE FREQUENCY (MHz)	USABLE FREQUENCY RANGE (MHz)	ACTIVE LENGTH (mm)
BLUE	560	510 - 620	125
BLACK	650	600 - 720	106
RED	750	700 - 800	88

NOTE: RX AND TX ANTENNA LENGTHS ARE SAME.

Active length is the length of the antennae from the connecting socket housing to the tip.

Model Variants and Switching Bands:

AWDR-1

AWDR-1dband

AWDR-1plus

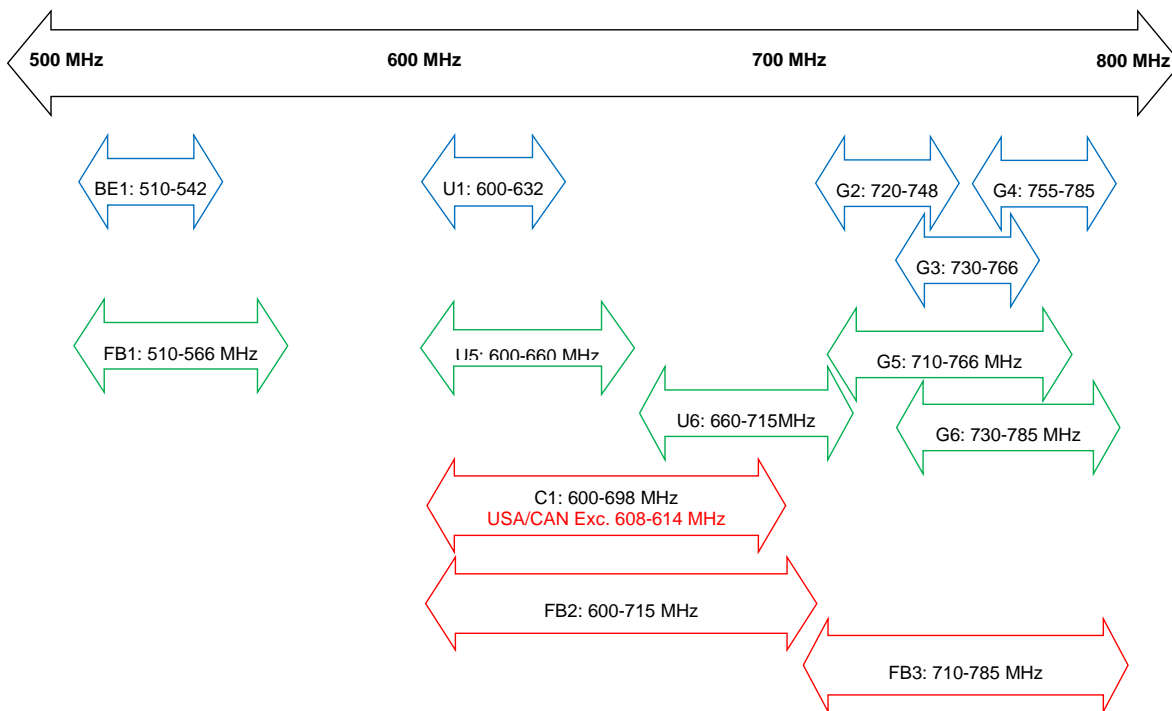

Audio Connector Details

There are two options of AF audio output connectors:

1. Small 4-pin HR4 Hirose connector - HR10-7P-4S

Pin 1:	0V Ground
Pin 2:	AF + Φ
Pin 3:	AF - Φ
Pin 4:	External Powering (with RCP cables)

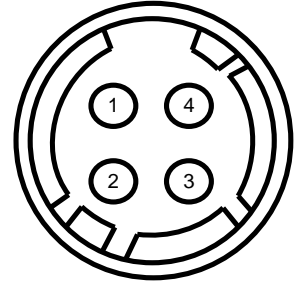

Please note Pin 2 & 3 are balanced audio output signal

2. Large 6-pin L6 LEMO connector – ERY.2C.306.CLL

Pin 1:	AF+ Φ
Pin 2:	Unused
Pin 3:	External Powering (with RCP cables)
Pin 4:	Unused
Pin 5:	0V Ground
Pin 6:	AF - Φ

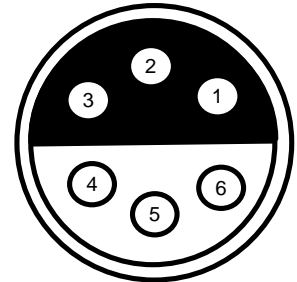

Please Note:

Please note the above chassis mounted connectors are shown as viewed from the external face, whereas the following cable connectors shown are from the solder side.

Cable End Connectors

1. XLR connector – NC3MX or Equivalent

Pin 1:	0V Ground
Pin 2:	AF + Φ
Pin 3:	AF - Φ
Ground spring:	Linked to Pin 1

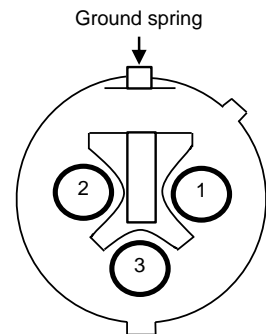

2. Small 4-pin Hirose (dc) connector – HR10-7P-4P

Pin 1:	0V Ground
Pin 2:	Unused
Pin 3:	Unused
Pin 4:	External Powering

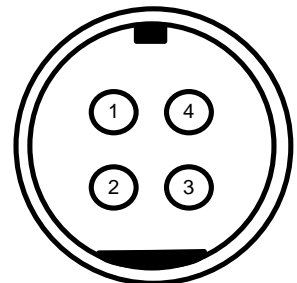

3. Small 4-pin Hirose (AF) connector – HR10-7P-4P

- Pin 1: 0V Ground
- Pin 2: AF + Φ
- Pin 3: AF - Φ
- Pin 4: External Powering

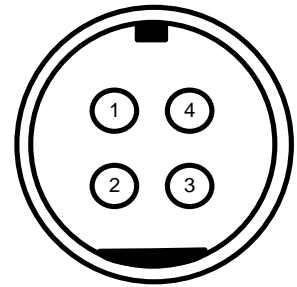

4. Large 6-pin L6 LEMO connector – FFA.2C.306.CLAL52

- Pin 1: AF+ Φ
- Pin 2: Unused
- Pin 3: External Powering (with RCP cables)
- Pin 4: Unused
- Pin 5: 0V Ground
- Pin 6: AF - Φ

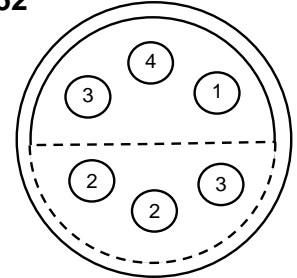

Standard Receiver Cables Details

RC-1HR4: Audio output cable to suit AWDR-1 (HR-4) receivers, balanced AF output to XLR

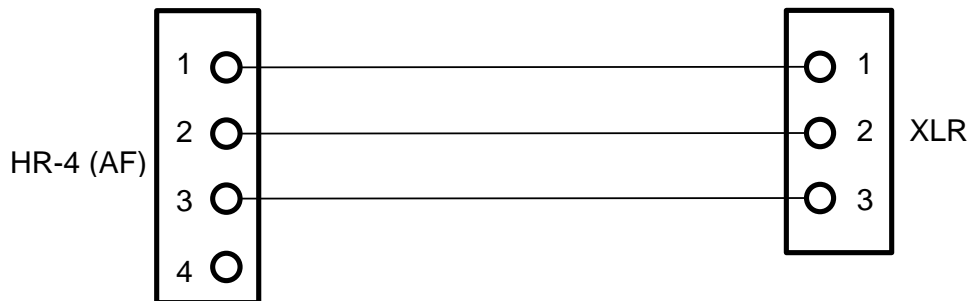

RCP-1HR4: Audio output and external powering cable for AWDR-1 (HR-4) receivers, external powering (10-18 V dc) with 4-pin Hirose (dc) connector, with balanced AF output to XLR

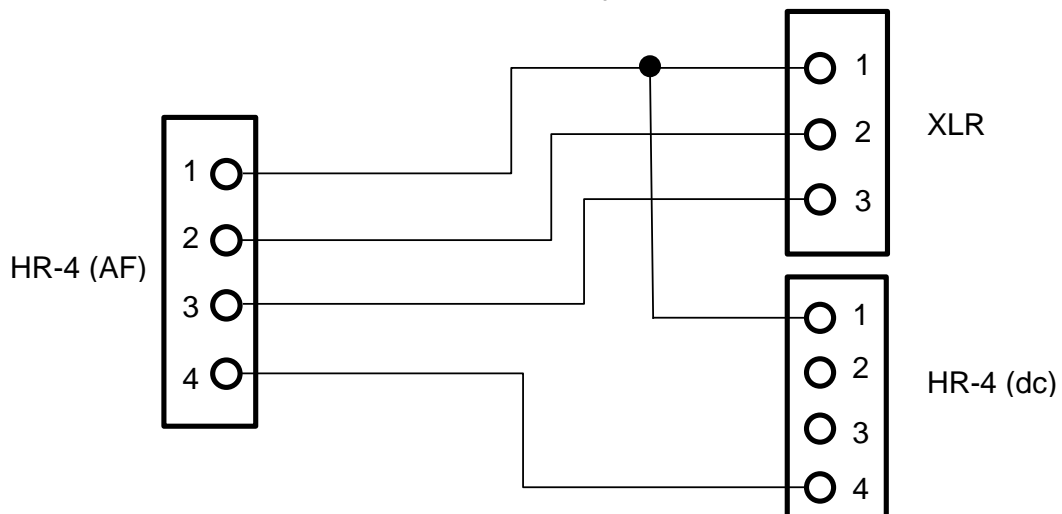

2RCP-1HR4: Dual audio output and external powering cable to power two AWDR-1 (HR-4) receivers, external powering (10-18 V dc) with 4-pin Hirose (dc) connector, with 2x balanced AF output to XLR

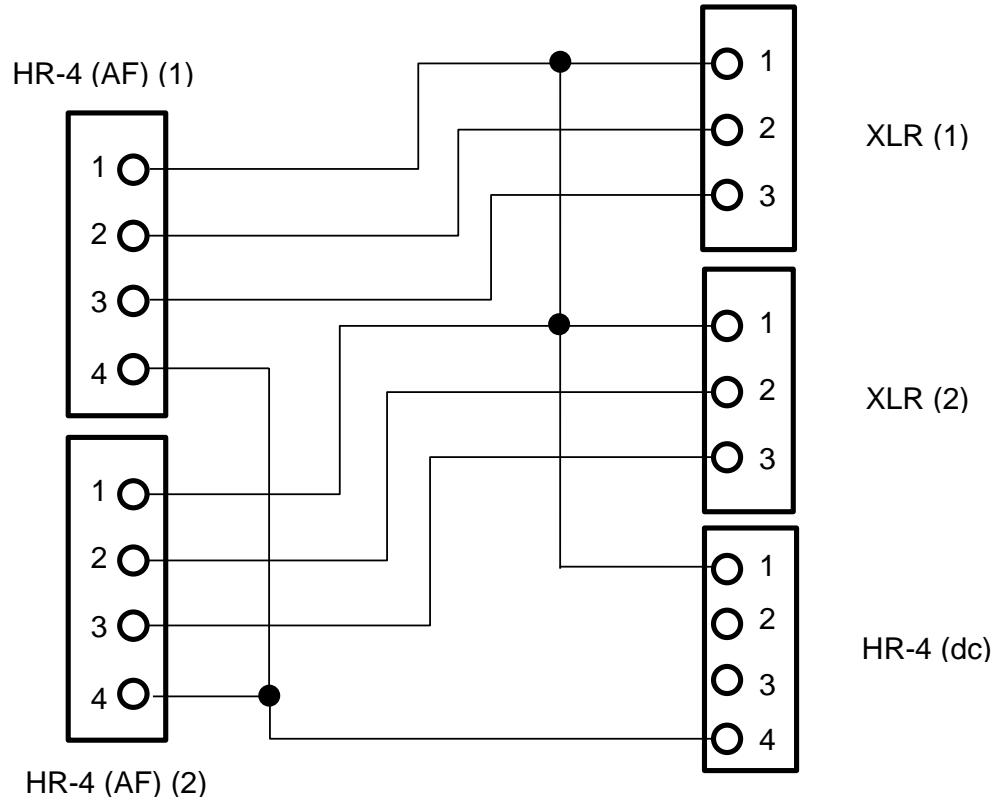

RC-1L6: Audio output cable to suit AWDR-1 (L6) receivers, balanced AF output to XLR

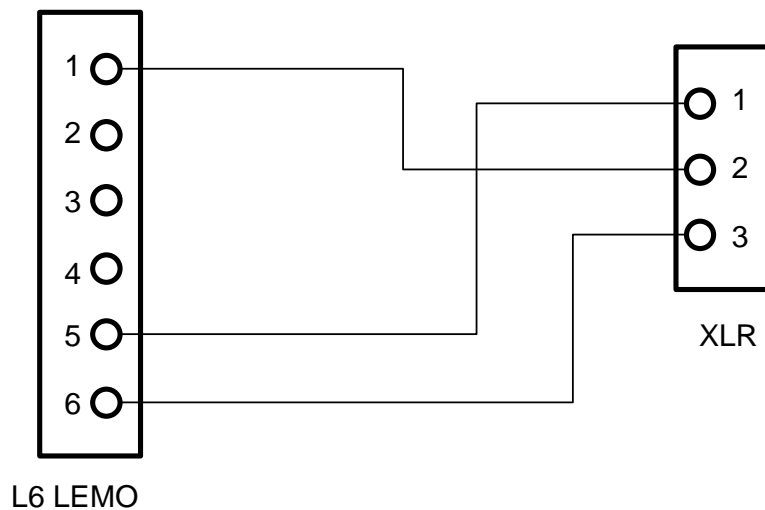

RCP-1L6: Audio output and external powering cable for AWDR-1 (L6) receivers, external powering (10-18 V dc) with 4-pin Hirose (dc) connector, with balanced AF output to XLR

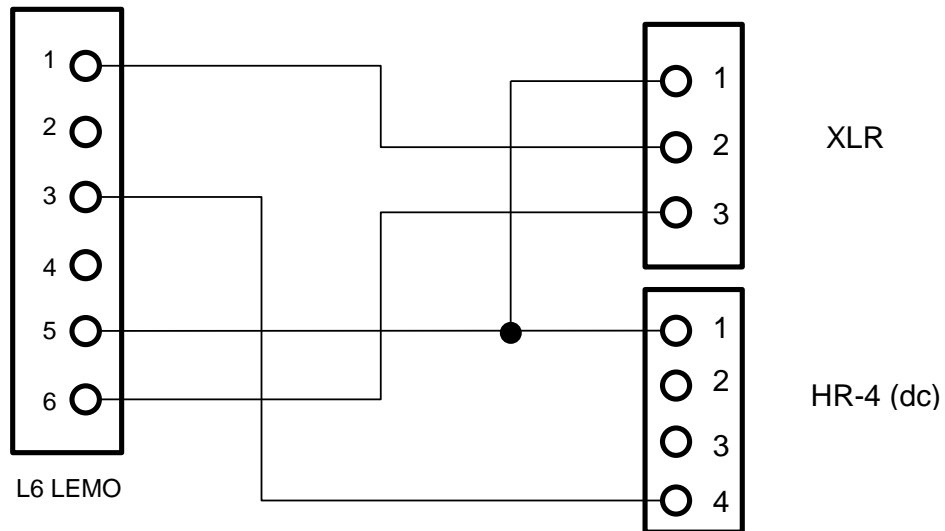

2RCP-1L6: Dual audio output and external powering cable to power two AWDR-1 (L6) receivers, external powering (10-18 V dc) with 4-pin Hirose (dc) connector, with 2x balanced AF output to XLR

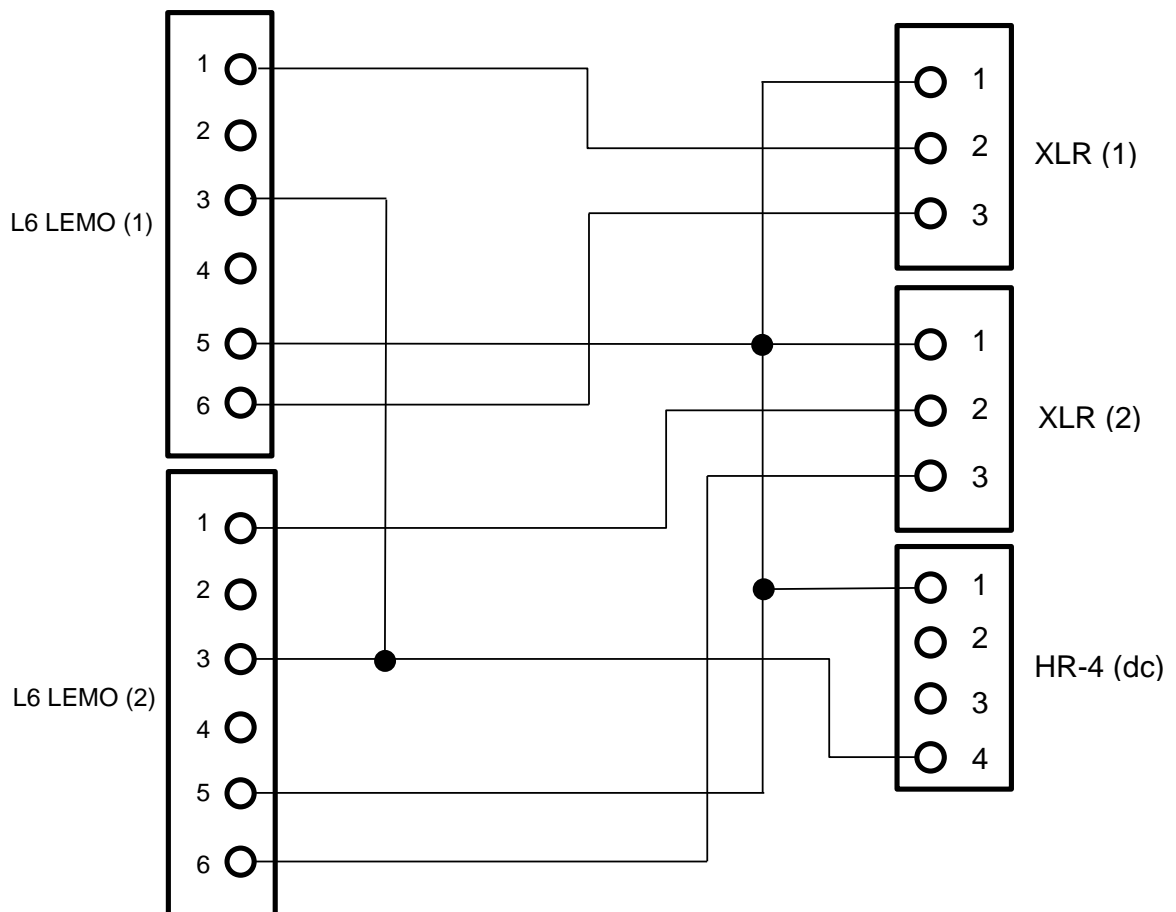

Technical Specifications

RF Transmission System

Carrier Range (to order)	470 to 790MHz
Channels	up to 4800, switchable in 25 kHz steps
Switching Range	up to 120MHz
Modulation System	F3EGN
Minimum Channel Spacing	300 kHz
Reference Deviation	40 kHz
Adjacent Channel Rejection	>100dB
Mute Level	4-steps: 0dB μ (nom), 5dB μ , 15dB μ , 25dB μ

Audio Performance

System S/N Ratio	>100dB
Frequency Response	60Hz to 18kHz, \pm 2dB
Distortion	<0.2% THD
AF Level	Balanced variable output, -42dBV to +6dBV

Received Signal Strength Indicators (RSSI) (Active A and Active B)

Green	signal >25 μ V
Amber	signal >5 μ V
Red	signal <5 μ V
No light	Muted

Battery Status Indicator

Green	>2.2V
Amber	>1.9V
Red	<1.8V
No light	Battery Flat (unit OFF)

TX Low Battery Indicator

Red LED lights when TX battery < 1.0V

Headphone Monitoring Output

AF Level	50mW
Impedance	16 Ohms

Powering

Battery Type	IEC LR6 (MN1500) 2 x AA
Current Consumption	250mA (max) @ 3V
Battery Life	approximately 5 Hours with alkaline battery
External Power	10.0 to 18V dc (with 'RCP' cables)

Connectors

Antenna Inputs	SMA connectors (x2)
Audio Output	4-pin Hirose or large 6-pin Lemo connector
Monitor Output	3.5mm jack socket (accepts mono or stereo)

Dimensions

Width	62mm (max) Depth: 20mm
Height	114mm (max) Weight: 200gr

Accessories

Supplied:

- Antennas (x2)
- Quick start guide

Optional extras

- RC: Receiver balanced audio output cable
- RCP: Receiver balanced audio output cable for external powering
- 2RCP: Dual balanced audio output cable for external powering of two receivers
- HSA: Hot shoe adapter

Audio Wireless Ltd reserves the right to change specifications without notice, as part of its policy of continuous product development. © Audio Wireless Ltd.



**Audio Wireless AWT-1
Transmitter**

Switching bandwidth up to
120MHz, for crews,
camera operators
and sound
recordists.



**Audio Wireless AWDR-1
Diversity Receiver**

Small, true-diversity receiver
for broadcast and location
recording applications,
switchable RF front-end
filtering.



**Audio Wireless
Monitoring Receivers**

Monitoring mobility for
presenters, directors
and crew, in broadcast
and film, in studio or on
location.



Printed in the UK
Published August 2013

Audio Wireless Ltd

Elstree Film Studios
Phoenix 5
Andrew Mitchell Building
Shenley Road, Borehamwood
Hertfordshire
WD6 1JG
UK

Telephone: +44 (0)20 8324 2375
www.audiowireless.co.uk
Email: enquiry@audiowireless.co.uk